

Maximum Rating Tables

Size 842 • GR, NH & EL Series



Single Reduction
Worm Gear Reducers

Double Reduction
Worm - Worm Gear Reducers

Double Reduction
Helical - Worm Gear Reducers

WASHGUARD® Reducers
and GEAR+MOTOR™

Ratio Multipliers

Accessories and
Additional Capabilities

Style B

Style H



Size 842

Ratio	nput RPM	Output RPM	nput HP	Output HP	Output Torque (lb in)	Left Hand Catalog No	Right Hand Catalog No	Double Extension Catalog No	Hollow Output Catalog No *
5	2500	500	20.79	19.87	2589	8420001	8420013	8420025	8420501.XX
	1750	350	18.08	17.25	3209				
	1170	234	15.18	14.43	4016				
7.5	100	20	2.751	2.376	7738	8420002	8420014	8420026	8420502.XX
	2500	333	18.84	17.83	3372				
	1750	233	16.27	15.36	4148				
10	1170	156	13.42	12.61	5094	8420003	8420015	8420027	8420503.XX
	100	13	2.342	1.931	9126				
	2500	250	17.39	16.37	4127				
15	1750	175	14.93	14.00	5042	8420004	8420016	8420028	8420504.XX
	1170	117	12.31	11.47	6180				
	100	10	2.051	1.629	10629				
20	2500	166	12.94	11.92	4507	8420005	8420017	8420029	8420505.XX
	1750	116	11.13	10.20	5508				
	1170	78	9.193	8.357	6752				
25	100	6.7	1.608	1.190	11245	8420006	8420018	8420030	8420506.XX
	2500	125	11.02	9.91	4999				
	1750	87	9.462	8.458	6092				
30	1170	58	7.816	6.913	7447	8420007	8420019	8420031	8420507.XX
	100	5.0	1.407	0.956	12056				
	2500	100	9.256	8.164	5145				
40	1750	70	7.940	6.946	6254	8420008	8420020	8420032	8420508.XX
	1170	46	6.551	5.658	7619				
	100	4.0	1.210	0.764	12038				
50	2500	83	7.517	6.455	4882	8420009	8420021	8420033	8420509.XX
	1750	58	6.481	5.517	5960				
	1170	39	5.384	4.518	7300				
60	100	3.3	1.066	0.636	12026	8420010	8420022	8420034	8420510.XX
	2500	62	6.101	5.013	5055				
	1750	43	5.262	4.274	6156				
80	1170	29	4.379	3.490	7520	8420011	8420023	8420035	8420511.XX
	100	2.5	0.920	0.480	12090				
	2500	50	5.088	4.029	5078				
100	1750	35	4.389	3.426	6170	8420012	8420024	8420036	8420512.XX
	1170	23	3.655	2.788	7510				
	100	2.0	0.804	0.375	11809				

How To Build a Part Number For Size GR842, NH842, EL842

1. Select partial catalog number from the selection table
2. Replace leading “_” with series code (GR, NH, EL)
3. For hollow output, replace “XX” suffix with bore code (see next page for codes)

Example:

Grove Gear IRONMAN, style B, 5:1 ratio, left hand output
 GR-B842-5-L
 GR8420001

Single Reduction
Worm Gear Reducers





Double Reduction
Worm - Worm Gear Reducers

Double Reduction
Helical - Worm Gear Reducers

WASHGUARD® Reducers
and GEAR+MOTOR™

Ratio Multipliers

Accessories and
Additional Capabilities

	Style BM			Style HM	Style BMQ			Style HMQ	
									
NEMA C nput Flange ▲	Left Hand Catalog No	Right Hand Catalog No	Double Extension Catalog No	Hollow Output Catalog No *	Left Hand Catalog No	Right Hand Catalog No	Double Extension Catalog No	Hollow Output Catalog No *	Ratio
182 4TC 213 5TC 254 6TC	8420109 8420145 8420181	8420121 8420157 8420193	8420133 8420169 8420205	8420537.XX 8420549.XX 8420561.XX	8420289 8420325 8420361	8420301 8420337 8420373	8420313 8420349 8420385	8420597.XX 8420609.XX 8420621.XX	5
182 4TC 213 5TC 254 6TC	8420110 8420146 8420182	8420122 8420158 8420194	8420134 8420170 8420206	8420538.XX 8420550.XX 8420562.XX	8420290 8420326 8420362	8420302 8420338 8420374	8420314 8420350 8420386	8420598.XX 8420610.XX 8420622.XX	7.5
182 4TC 213 5TC 254 6TC	8420111 8420147 8420183	8420123 8420159 8420195	8420135 8420171 8420207	8420539.XX 8420551.XX 8420563.XX	8420291 8420327 8420363	8420303 8420339 8420375	8420315 8420351 8420387	8420599.XX 8420611.XX 8420623.XX	10
182 4TC 213 5TC	8420112 8420148	8420124 8420160	8420136 8420172	8420540.XX 8420552.XX	8420292 8420328	8420304 8420340	8420316 8420352	8420600.XX 8420612.XX	15
182 4TC 213 5TC	8420113 8420149	8420125 8420161	8420137 8420173	8420541.XX 8420553.XX	8420293 8420329	8420305 8420341	8420317 8420353	8420601.XX 8420613.XX	20
143 5TC 182 4TC 213 5TC	8420078 8420114 8420150	8420090 8420126 8420162	8420102 8420138 8420174	8420530.XX 8420542.XX 8420554.XX	8420258 8420294 8420330	8420270 8420306 8420342	8420282 8420318 8420354	8420590.XX 8420602.XX 8420614.XX	25
143 5TC 182 4TC	8420079 8420115	8420091 8420127	8420103 8420139	8420531.XX 8420543.XX	8420259 8420295	8420271 8420307	8420283 8420319	8420591.XX 8420603.XX	30
143 5TC 182 4TC	8420080 8420116	8420092 8420128	8420104 8420140	8420532.XX 8420544.XX	8420260 8420296	8420272 8420308	8420284 8420320	8420592.XX 8420604.XX	40
143 5TC 182 4TC	8420081 8420117	8420093 8420129	8420105 8420141	8420533.XX 8420545.XX	8420261 8420297	8420273 8420309	8420285 8420321	8420593.XX 8420605.XX	50
56C 143 5TC 182 4TC	8420046 8420082 8420118	8420058 8420094 8420130	8420070 8420106 8420142	8420522.XX 8420534.XX 8420546.XX	8420226 8420262 8420298	8420238 8420274 8420310	8420250 8420286 8420322	8420582.XX 8420594.XX 8420606.XX	60
56C 143 5TC	8420047 8420083	8420059 8420095	8420071 8420107	8420523.XX 8420535.XX	8420227 8420263	8420239 8420275	8420251 8420287	8420583.XX 8420595.XX	80
56C 143 5TC	8420048 8420084	8420060 8420096	8420072 8420108	8420524.XX 8420536.XX	8420228 8420264	8420240 8420276	8420252 8420288	8420584.XX 8420596.XX	100

For input/ output shaft overhung load and thrust load ratings, refer to pages 419-422.

▲ Consult Factory for other motor flanges available.

* Catalog numbers are for hollow output shaft reducers.

When ordering, substitute the XX suffix with the required output bore code.

Available bore codes

Fraction Size	1-7/16"	1-1/2"	1-5/8"	1-11/16"	1-3/4"	1-7/8"	1-15/16"	2"	2-3/16"
Decimal Size	1.438	1.500	1.625	1.688	1.750	1.875	1.938	2.000	2.188
Output Bore Code	23	24	26	27	28	30	31	32	35



NH Series Dimensions

Styles: BMQ, BM, B

CAST IRON
NH SERIES

Single Reduction
Worm Gear Reducers

Double Reduction
Worm - Worm Gear Reducers

Double Reduction
Helical - Worm Gear Reducers

WASHGUARD® Reducers
and GEAR+MOTOR™

Ratio Multipliers

Accessories and
Additional Capabilities

Style BMQ

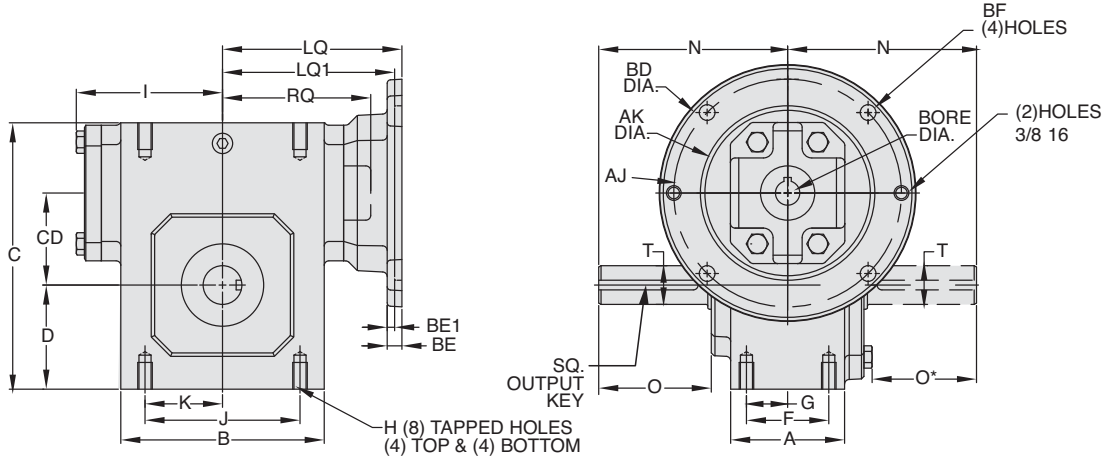

Style BM

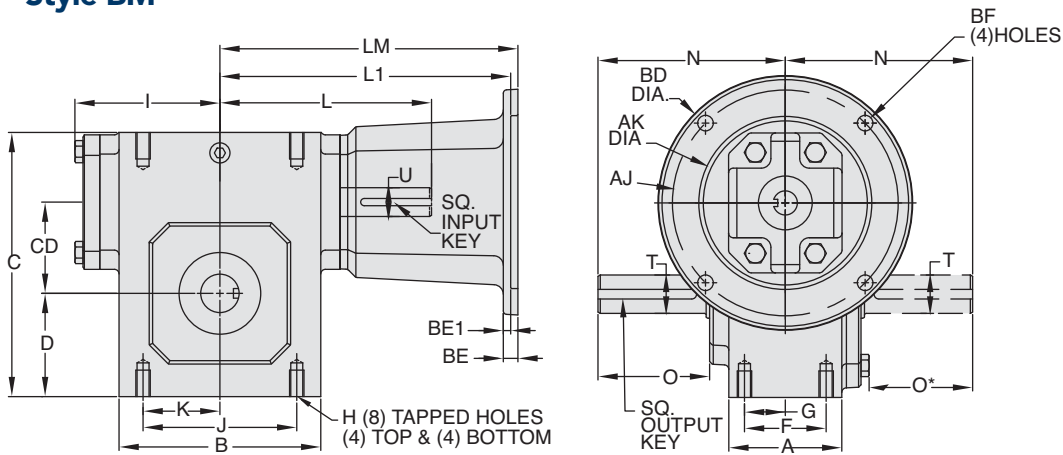

Style B

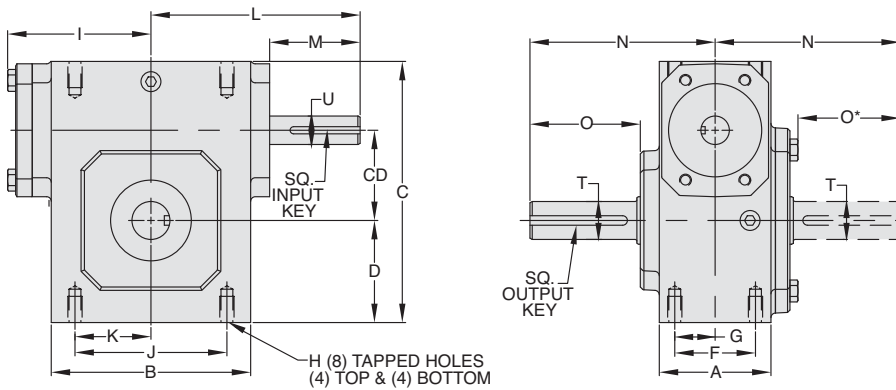

ASSEMBLIES

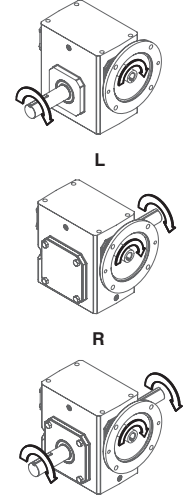

ASSEMBLIES

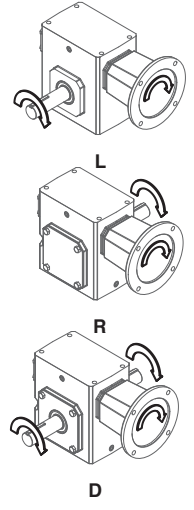

ASSEMBLIES

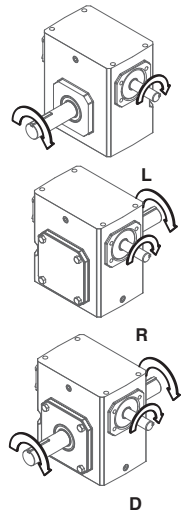

REVERSE ALL ARROWS FOR OPPOSITE INPUT SHAFT ROTATION. CONTACT FACTORY FOR OTHER MOUNTINGS OR ASSEMBLY POSITIONS.

REVERSE ALL ARROWS FOR OPPOSITE INPUT SHAFT ROTATION. CONTACT FACTORY FOR OTHER MOUNTINGS OR ASSEMBLY POSITIONS.



NH Series Dimensions

Styles: BMQ, BM, B



Single Reduction
Worm Gear Reducers

Double Reduction
Worm - Worm Gear Reducers

Double Reduction
Helical - Worm Gear Reducers

WASHQUARD® Reducers
and GEAR+MOTOR™

Ratio Multipliers

Accessories and
Additional Capabilities

STYLE BMQ, BM, B DIMENSIONS (Inches)

Size	A	B	C	CD	D	F	G	H		I	J	K	L	M	N	O	O*	T +0.000 -0.0015	U +0.000 -0.0015	Input Key**	Output Key
								Tap Size	Depth												
NH813	2.82	3.80	4.66	1.33	1.72	2.00	1.00	5/16-18 UNC	.50	2.61	3.25	1.63	3.82	1.76	4.00	2.16	1.94	0.750	0.500	1/8 X 1.00	3/16 X 1.50
NH815	2.57	4.06	5.00	1.54	1.88	1.88	0.94	5/16-18 UNC	.63	3.14	3.25	1.63	4.35	1.76	4.25	2.56	2.35	0.750	0.625	3/16 X 1.38	3/16 X 1.50
NH818	2.56	4.50	5.44	1.75	2.06	1.88	0.94	5/16-18 UNC	.63	3.24	3.75	1.88	4.45	1.76	4.75	2.94	2.73	1.000	0.625	3/16 X 1.38	1/4 X 1.75
NH821	2.50	4.50	6.00	2.06	2.31	1.88	0.94	5/16-18 UNC	.63	3.61	3.25	1.63	4.82	1.76	4.34	2.66	2.45	0.875	0.625	3/16 X 1.38	3/16 X 1.50
NH824	2.94	5.25	6.88	2.38	2.69	2.13	1.06	3/8-16 UNC	.69	3.77	4.00	2.00	5.51	2.38	4.88	2.91	2.69	1.000	0.750	3/16 X 1.63	1/4 X 1.75
NH826	2.88	5.75	7.38	2.63	2.94	2.13	1.06	3/8-16 UNC	.69	4.34	4.00	2.00	6.07	2.38	5.25	3.28	3.07	1.125	0.750	3/16 X 1.63	1/4 X 1.75
NH830	3.12	6.62	8.25	3.00	3.38	2.38	1.19	3/8-16 UNC	.75	4.84	4.63	2.31	6.57	2.38	5.77	3.56	3.31	1.250	0.875	3/16 X 1.63	1/4 X 1.75
NH832	4.44	8.00	10.06	3.25	4.19	3.50	1.75	1/2-13 UNC	1.00	5.02	7.00	3.50	6.76	2.38	7.03	4.24	3.99	1.500	0.875	3/16 X 1.63	3/8 X 2.25
NH842	4.75	9.75	11.50	4.25	4.50	3.75	1.88	1/2-13 UNC	1.00	6.10	7.50	3.75	9.57	3.47	7.50	3.88	3.59	1.750	1.250	1/4 X 2.50	3/8 X 2.25
NH852	6.19	11.00	12.69	5.25	4.88	4.50	2.25	5/8-11 UNC	1.25	7.50	9.00	4.50	10.88	3.38	9.00	4.72	4.47	2.000	1.250	1/4 X 3.00	1/2 X 2.50

Motor Mounting Dimensions

NEMA DIMENSIONS (Inches)

Size	LM		L1		LQ 48CZ/ 56C/140TC	180TC	LQ1		RQ			
	48CZ	56C/ 140TC	180TC/ 210TC	250TC			180TC	210TC	250TC	48CZ/ 56C/140TC	180TC	210TC
NH813	5.63	6.07	N/A	N/A	3.46	N/A	N/A	N/A	3.09	N/A	N/A	N/A
NH815	6.16	6.60	N/A	N/A	3.99	N/A	N/A	N/A	3.62	N/A	N/A	N/A
NH818	6.26	6.70	N/A	N/A	4.09	N/A	N/A	N/A	3.59	N/A	N/A	N/A
NH821	6.63	7.07	N/A	N/A	4.46	N/A	N/A	N/A	4.06	N/A	N/A	N/A
NH824	N/A	7.76	8.76	N/A	4.63	5.06	N/A	N/A	4.09	4.56	N/A	N/A
NH826	N/A	8.32	9.32	N/A	5.19	5.62	N/A	N/A	4.82	5.13	N/A	N/A
NH830	N/A	8.82	9.82	N/A	5.69	6.12	6.56	N/A	5.32	5.63	6.06	N/A
NH832	N/A	9.01	10.01	N/A	5.88	6.31	6.75	N/A	5.51	5.81	6.25	N/A
NH842	N/A	11.81	12.90	13.46	6.77	7.21	7.21	7.77	6.04	6.68	6.68	7.24
NH852	N/A	13.21	14.30	14.86	7.85	8.61	8.61	9.17	7.35	7.98	7.98	8.54

NEMA DIMENSIONS (Inches)

Frame	AJ	AK	BD	BE	BE1	Bore Dia.	Keyway♦	BF
48CZ	3.75	3.00	4.36	0.38	N/A	0.500	1/8 X 1/16	0.28
56C	5.88	4.50	6.50	0.38	N/A	0.625	3/16 X 3/32	0.41
140TC	5.88	4.50	6.50	0.38	N/A	0.875	3/16 X 3/32	0.41
180TC	7.25	8.50	9.00	N/A	0.50	1.125	1/4 X 1/8	0.53
210TC	7.25	8.50	9.00	N/A	0.50	1.375	5/16 X 5/32	0.53
250TC	7.25	8.50	9.00	N/A	0.50	1.625	3/8 X 3/16	0.53

IEC B5 & B3/B5 METRIC DIMENSIONS (Inches)♦

Size	LQ1					RQ						
	D63D	D71D	D80D	D90D	D100LD/ D112MD	D132D	D63D	D71D	D80D	D90D	D100LD/ D112MD	D132D
NH813	2.62	2.65	2.89	N/A	N/A	N/A	2.45	2.47	2.71	N/A	N/A	N/A
NH815	3.15	3.18	3.42	N/A	N/A	N/A	2.98	3.00	3.24	N/A	N/A	N/A
NH818	3.25	3.28	3.52	N/A	N/A	N/A	2.95	2.97	3.21	N/A	N/A	N/A
NH821	3.62	3.65	3.89	N/A	N/A	N/A	3.43	3.44	3.68	N/A	N/A	N/A
NH824	N/A	3.72	4.34	N/A	N/A	N/A	N/A	3.46	3.71	N/A	N/A	N/A
NH826	N/A	4.28	4.90	4.90	5.30	N/A	N/A	4.09	4.72	4.72	5.07	N/A
NH830	N/A	4.78	5.41	5.41	5.80	N/A	N/A	4.59	5.22	5.22	5.57	N/A
NH832	N/A	4.97	5.59	5.59	5.99	N/A	N/A	4.78	5.41	5.41	5.76	N/A
NH842	N/A	N/A	N/A	6.38	6.39	7.17	N/A	N/A	N/A	6.16	6.14	6.93
NH852	N/A	N/A	N/A	7.78	7.78	8.57	N/A	N/A	N/A	7.46	7.45	8.24

IEC B5 & B3/B5 METRIC DIMENSIONS (MM)

Frame	AJ	AK	BD	BE	Bore Dia.	Keyway♦	BF TAP	OD
D63D	115	95	117	10	11	4 X 2	M8 X 1.25	131
D71D	130	110	132	11	14	5 X 2.5	M8 X 1.25	146
D80D	165	130	165	15	19	6 X 3	M10 X 1.50	184
D90D	165	130	165	15	24	8 X 3.5	M10 X 1.50	184
D100LD/ D112MD	215	180	216	18	28	8 X 3.5	M12 X 1.75	237
D132D	265	230	267	18	38	10 X 4	M12 X 1.75	290

- * Applies to double output shaft
- ♦ Keyway width by depth
- 48CZ not available
- ♦ Metric IEC B5 input flange options are available only on quill input styles.
- * Style B and BM only.



For safety, purchaser or user should provide protective guards over shaft extensions and any couplings, sheaves and belts, sprockets and chains, etc., mounted thereon.

GROVE GEAR OE SERIES INTERCHANGE GUIDE

Grove Gear OE Series	Grove Gear IRONMAN NH Series
UF	BMQ
UFC	BM
U	B

Refer to page 8 for complete interchange guide for original Grove Gear OE Series products.